

Design and Test of Fast Laser Driver Circuits

Since the invention of the laser by Theodore H Maiman 50 years ago, lasers have found widespread applications in various technological fields, such as telecommunications, industrial production [\[1\]](#), and sensor and measurement equipment. While the focus in communications is on achieving high transmission frequencies in the GHz range, in industrial production the main objective is often high, pulsed light power in the ultra-short nanosecond range. In laser sensor and measurement applications the challenges of the design of fast driver circuits is a very demanding task. This White Paper describes the design of fast driver circuits, PCB layouts and optical measurement considerations, as well as a solution to achieve an ideal design for pulses as short as 2.5 ns.

Table of contents

- 1) [Integrated laser driver solutions](#)
- 2) [Design considerations of fast laser driver circuits](#)
- 3) [Layout requirements](#)
- 4) [Measuring laser pulses](#)
 - 4.1) [From an Oscilloscope to an optical Scope](#)
 - 4.2) [From a PC to an optical USB Scope](#)
- 5) [Design checklist](#)
- 6) [Summary](#)
- 7) [Literature](#)

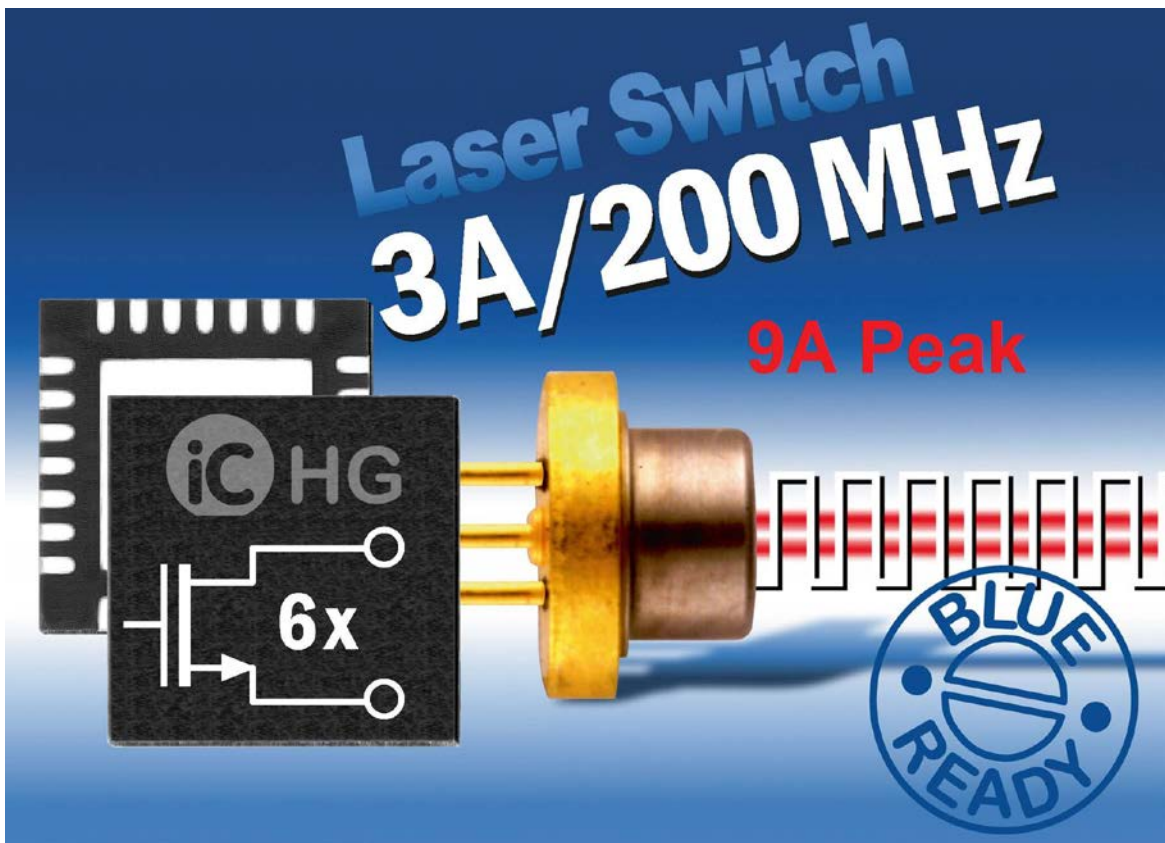

1) Integrated laser driver solutions

Conventional laser diode driver circuits commonly use discrete components for low cost along with low performance requirements [2]. The advantages of integrated laser driver solutions are:

- ✓ Improved output power stability (1% or better)
- ✓ Reduction of board space (up to 80%)
- ✓ Error monitoring
- ✓ Better dynamic performance
- ✓ Improved reliability/MTBF

For fast switching, integrated drivers are mandatory because of the reduced wiring line inductance and capacitance allowing faster signal changes.

2) Design considerations of fast laser driver circuits

The laser light sources deployed in measurement and sensor technology are usually semiconductor diode lasers with an optical output power of a few μW to several hundred mW. They can be easily and safely controlled by integrated circuits [3] and cover the entire visible spectrum right down to the infrared range. A complete overview of integrated laser drivers from iC-Haus can be found [here](#). The latest generation of all-purpose integrated laser driver solutions supports switching frequencies up to 155 MHz and laser currents up to 300 mA. Fig. 1 shows the schematic of an [iC-NZN](#) application. It operates from 3.3 to 5.5 V and can drive N, M, and P-type laser diodes with or without monitor diode.

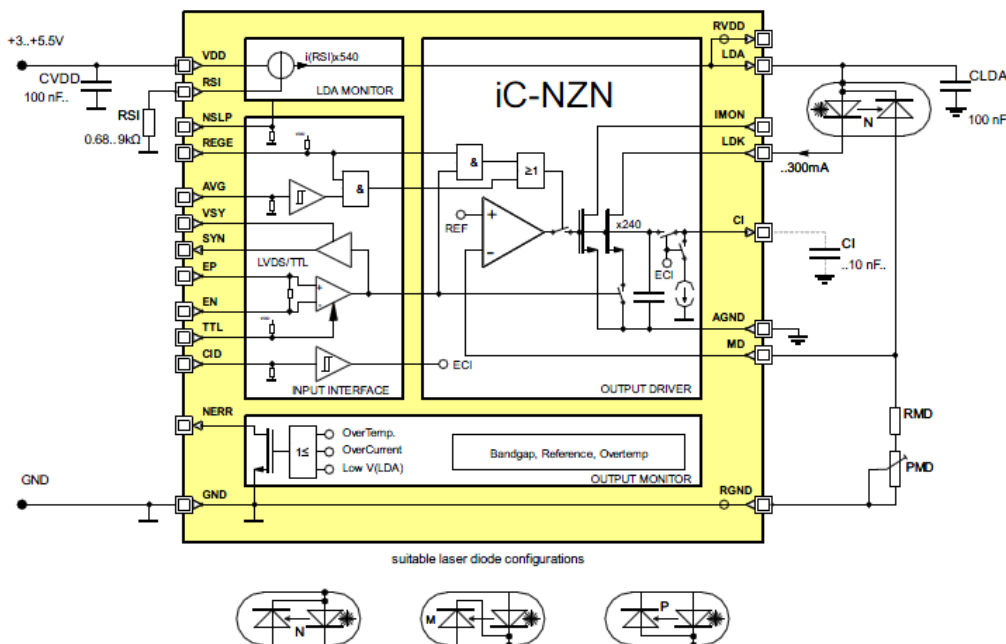

Figure-1: All-purpose laser driver circuit

Both operation modes, automatic power control (APC) and automatic current control (ACC), are supported [4]. The optical output power resp. the driver current is set by resistor PMP/RMD, as shown in Fig. 1 above. With a proper PCB layout the achievable pulse width can be as low as 3.5 ns with a pulse rise and fall time (t_r/t_f) of 1.5 ns (max). In this case LVDS input signals should be used instead of TTL levels to reduce EMI. While the [iC-NZN](#) features a low-side output (optimized for N-type laser diodes), the [iC-NZP](#) features a high-side output (optimized for P-Type laser diodes). To protect the laser diode, in particular in APC mode, the maximum driver current through pin VDDA can be limited by means of resistor RSI.

For laser pulses with higher power, the current switch such as the [iC-HG](#) provides an integrated solution. It features six spike-free current switches with 500 mA each and can be paralleled to drive up to three amps of DC current. Fig. 2 shows an application circuit for the [iC-HG](#), driving a single laser diode with 3 A. The pulse width can be as low as 2.5 ns at up to 9 A peak current. The maximum switching frequency is 200 MHz with rise and fall times of 1 ns (max). The maximum duty cycle depends on the power dissipation and cooling of the [iC-HG](#).

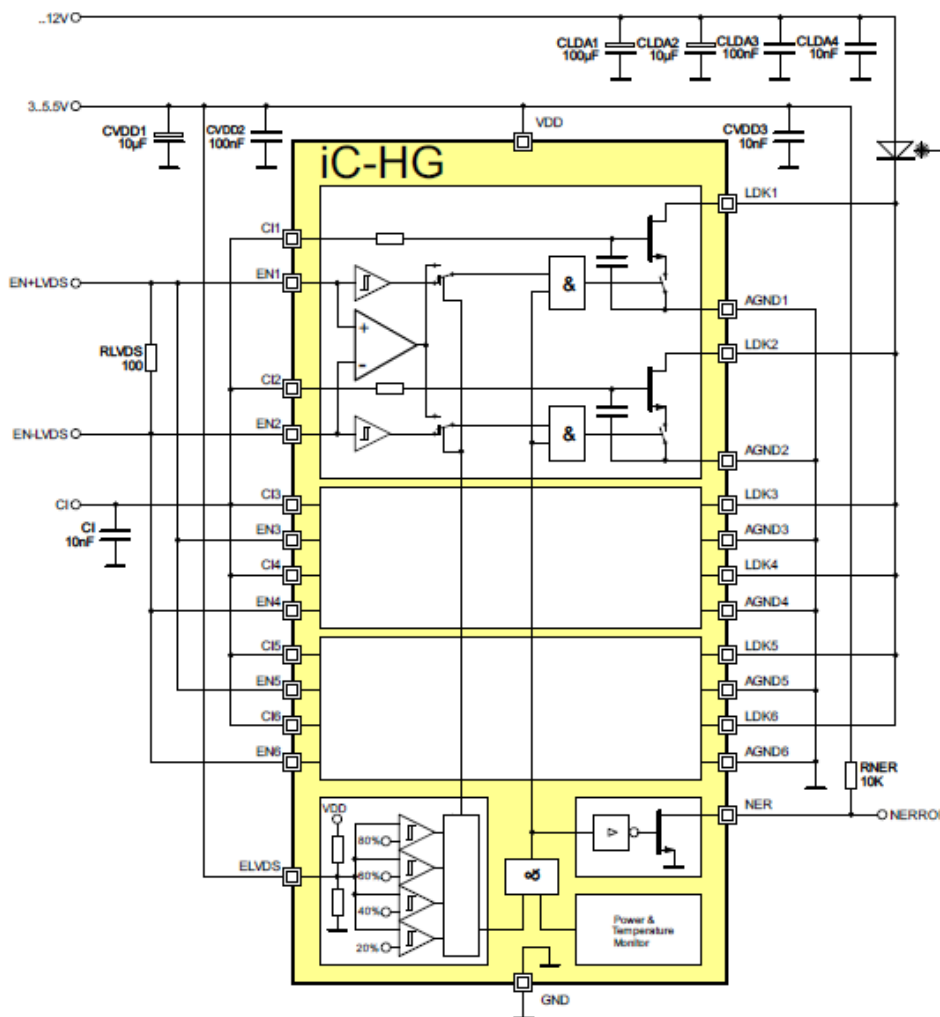

Figure-2: Laser driver circuit for up to 3 A CW or 9 A pulses

The EN1 and EN2 inputs are used in the LVDS mode with $100\ \Omega$ line termination. The laser supply voltage (12 V max.) is buffered with two low ESR tantalum capacitors and two ceramic capacitors for RF filtering. The **iC-HG** monitors the LVDS inputs and generates an error signal at NER, if the signal amplitude falls below 50%. The supply voltage and chip temperature is also monitored. On undervoltage and overload the NER signals an error. The current for each channel can be set by means of a control voltage at Clx. It can also be used for analog modulation. The maximum modulation frequency is typically around 2 MHz, with the input capacitance at Clx being the limiting factor.

3) Layout requirements

The layout of the laser driver module is critical for very short laser pulses. Due to the fast switching transients, a low line inductance is critical to keep in mind when designing the PCB. Fig. 3a shows an example of an **iC-HG** high-speed driver module and Fig. 3b the layout details. The recommended layout guidelines are as follows:

- Keep the lines from the driver to the laser diode and back as short as possible (every mm counts!)
- Place storage/bypass capacitors very close to the supply and ground of the driver IC
- Choose low ESR capacitors (using two capacitor in parallel will reduce ESR)
- Separate the ground planes for the AGNDx and GND (only connected at the common ground)
- Make use of the exposed pad of the DFN package for cooling

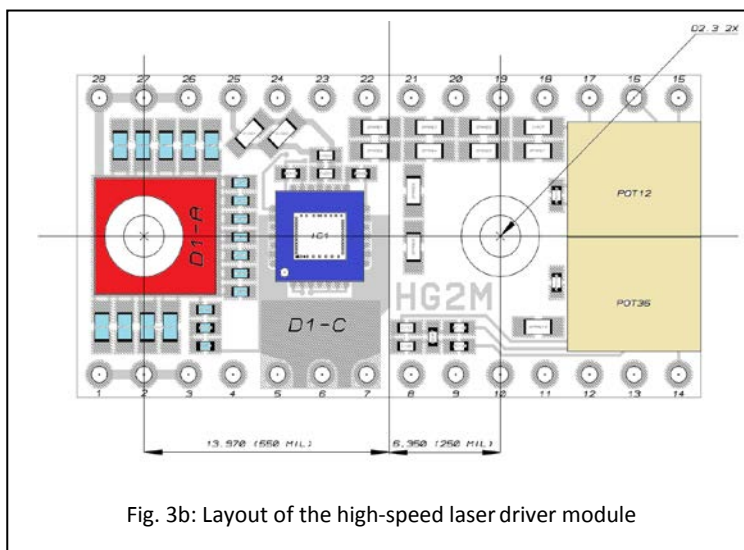
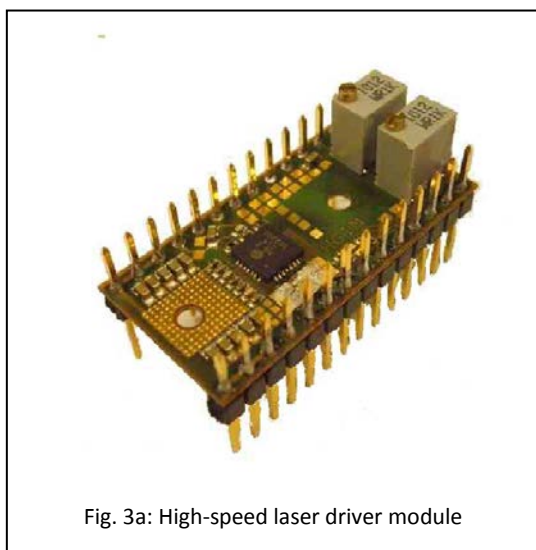

4) Measuring laser pulses

To know the exact shape of a laser pulse, an electrical measurement of only the laser current is not sufficient. The result will be quite different due to the characteristic of the laser diode. Thus, it is mandatory to measure the optical output of the laser diode. This is often achieved using an extension to the regular lab equipment for electronic measurements. Possible solutions include expanding the regular oscilloscope or the lab PC to be able to optically measure laser beams.

4.1) From an Oscilloscope to the optical Scope

For the optical measurement of laser diode pulses with a fast oscilloscope, an additional high-speed photo receiver is required. The photo receiver should have a high level of sensitivity in the relevant spectral range and as high a bandwidth as possible, from DC to the GHz range, so that both the amplitude of the laser pulses as well as the fast pulse edges can be measured.

Typical measurement setup

Fig. 4a shows a typical optical measurement setup with the [iC212](#) high-speed photo receiver being used as an adapter for the oscilloscope. In this example, a 40 mW laser generates pulses of approximately 12.5 ns where the amplitude and rise time are to be measured using the oscilloscope. The oscilloscope of course requires a suitably high analog bandwidth, which runs well into the GHz range, too. Fig. 4b shows the optical pulse response.

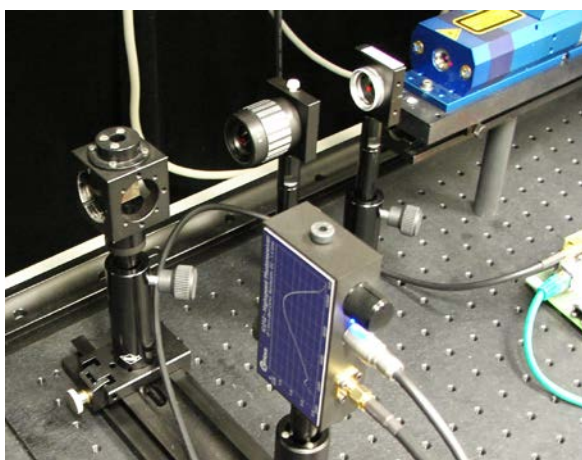

Figure 4a: Optical measurement setup for laser diodes and modules with photo receiver iC212

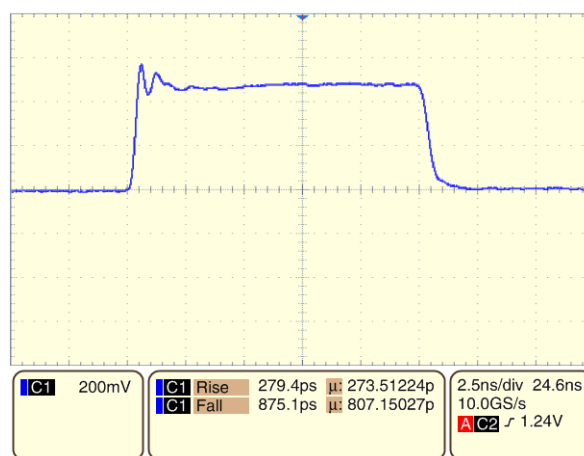

Figure 4b: Resulting light pulse measured by photo receiver iC212

The [iC212](#) has been specifically designed as a photo receiver for such types of measurement. It is the first device of its kind to combine a bandwidth that ranges from DC to 1.4 GHz with a wide spectral sensitivity of 320 to 1,000 nm (see Fig. 5). It can thus measure both continuous wave and pulse light power as well as transients down to 280 ps.

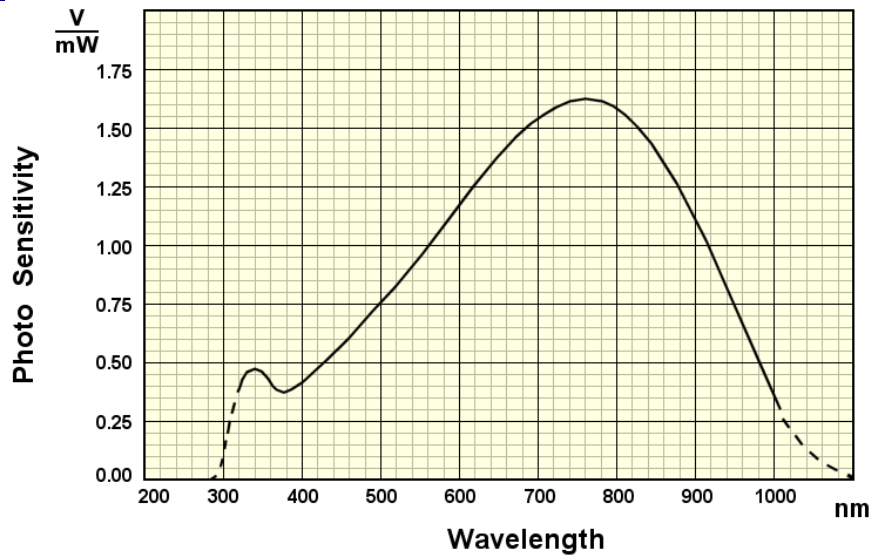

Figure 5: Spectral sensitivity of the photoreceiver

The [iC212](#) gain factor is 1.625 V/mW at $\lambda = 760$ nm. This enables an optical power to be measured down into the sub-mW range. The rise and fall times of the laser pulses can be read directly off the oscilloscope. The optical power can then be calculated from the measured amplitude divided by the sensitivity at the relevant wavelength.

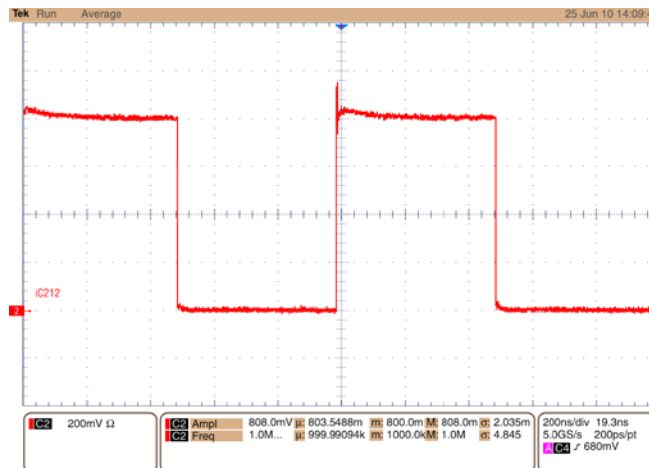

Figure 6: Measuring power

Fig. 6 shows the oscilloscope measurement at a wavelength of $\lambda = 635$ nm. The sensitivity computed from Fig. 5 is $S = 1.34$ V/mW at $\lambda = 635$ nm. The optical power is then calculated using the following equation, with U being the amplitude read from the oscilloscope:

$$P_{opt}(iC212) = U / S = 0.803 \text{ V} / 1.34 \text{ V/mW} = 0.60 \text{ mW}$$

Besides the optical measurement of laser diodes and laser modules, the [iC212](#) can also be used to measure glass fiber transmission lines, optical time of flight, and irradiance, or as an optical trigger for the testing of and/or error detection in laser systems.

4.2 From a PC to an optical USB Scope

Another option is to attach an [iC227](#) digital oscilloscope to a lab PC's USB port. It is a very fast and accurate dual channel 8 GHz sequential sampling oscilloscope, based on a microcontroller and high speed ECL differential circuitry. The microcontroller communicates via an isolated USB interface running in full speed mode at 12 Mbits/s. The sequential scope operates by inserting incremental delays between the trigger and sample circuit. The ADC conversion starts with a trigger event and begins sampling in 10 picoseconds increments. Fig. 7 shows the functional principles of the [iC227](#) configured as a 4 GHz oscilloscope with two channels. The connection to the unit under test would be a photo receiver like the [iC212](#) to have a complete optical Scope on a PC.

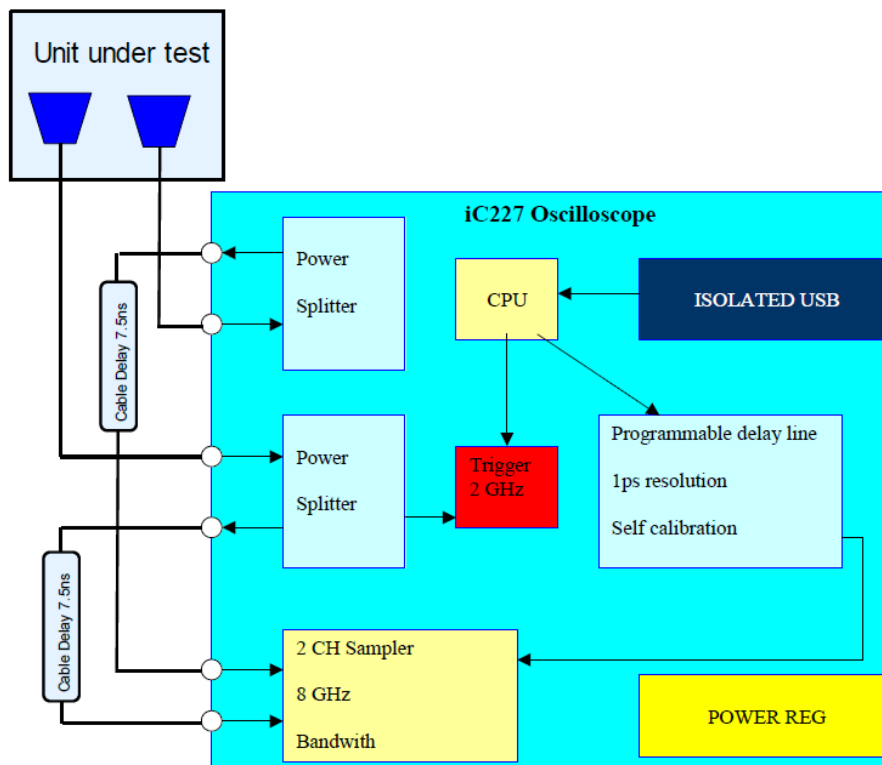

Figure-7: Functional principle of the USB oscilloscope

The [iC227](#) key features are:

- 8 GHz bandwidth on CH1 and CH2
- Trigger input bandwidth 2 GHz
- Time base range 25 ps to 100 μ s
- Vertical 12 bit resolution
- Time base accuracy 0.5% FS +/-10 ps
- Vertical accuracy with direct CH1/CH2 Inputs 3% FS
- Min. trigger frequency 10 kHz
- Vertical divisions 10 to 1000 mV
- Maximum input voltage sampler 2 Vpp, Trigger 4 Vpp

The [iC227](#) will work with repetitive signals only due to sampling operating principle. Hence a digital pulse generator is required to complete the test setup. Fig. 8 shows the [iC149](#) pulse generator. It generates pulses with 1 to 64 ns in increments of 0.25 ns. The frequency is a fixed 1 MHz and supplied at the LVDS and TTL outputs. The pin connector is compatible with the evaluation boards of the [iC-HG](#) and [iC-NZN/NZP](#).

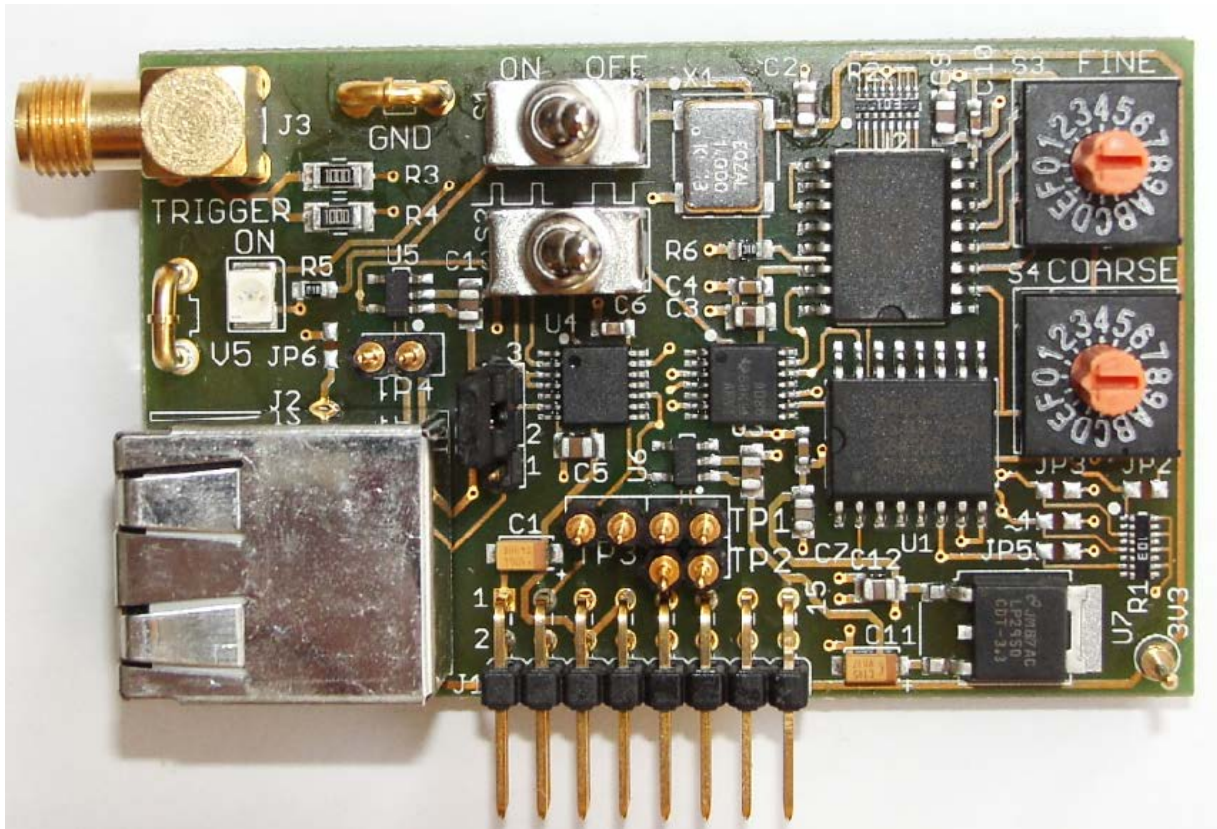

Figure-8: Pulse generator with a pin connector to the iC-HG/NZN/NZP Eval-Boards

The pulse width can be set by two hex-coded rotary switches. By way of example, a complete test set-up is shown in Fig. 9. It consists of an optical test bench with the [iC-NZN](#) evaluation board and the pulse generator [iC149](#) attached. On the receiver side the [iC212](#) photo receiver is used together with the [iC227](#) which is set for 8 GHz bandwidth. The output of the [iC212](#) photo receiver is connected directly to channel 1. The "Input via Trigger" box for channel 1 must be unchecked.

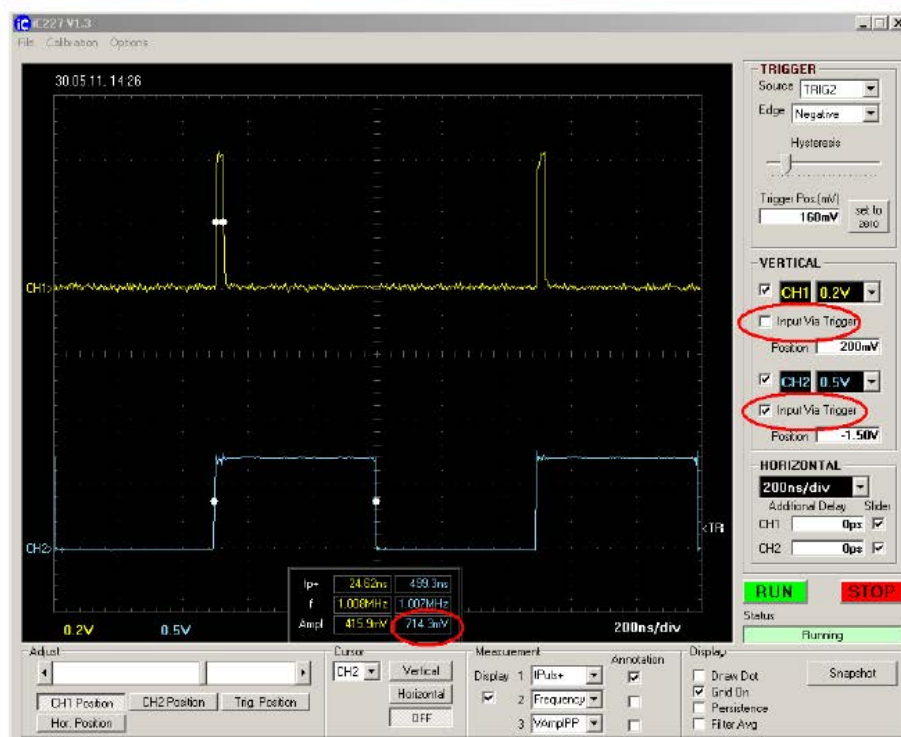
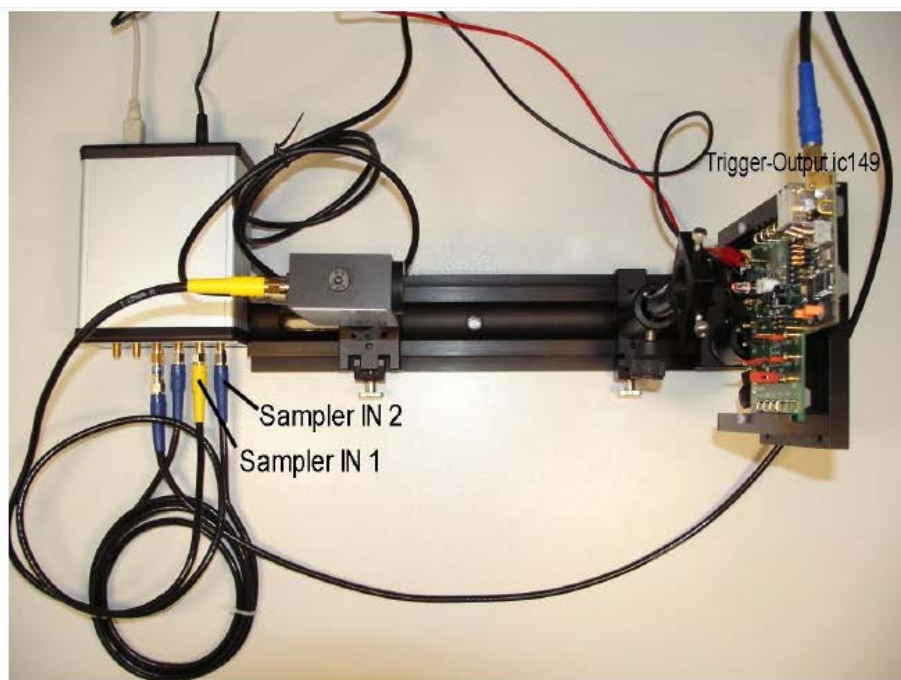

Figure-9: Optical measurement with the PC USB optical Scope

The output of the [iC212](#) photo receiver is connected directly to "SAMPLER IN1".The "Input via Trigger" box of channel 1 must be unchecked.

5) Design checklist

For a high-speed laser driver design, it is recommended to closely consider the following items:

- Layout rules according to listing in [paragraph 3](#)
- Bandwidth of the oscilloscope (is it sufficient to see the fast transitions and overshooting).
- Overshooting on the [iC-HG](#)'s (LDKx outputs should not exceed the 12 V maximum).
- Overshooting on the [iC-NZN](#)'s (LDK output should not exceed 15 V maximum, 12 V nominal)

6) Summary

New generations of laser driver circuits based on [iC-HG](#) are able to generate high-power laser pulses down to 3.5 ns as shown. To actually achieve this in the respective application, an optimized PCB design is required to minimize inductances. Special tools are needed to measure the optical output as well as rise and fall times. The photo receiver [iC212](#), the pulse generator [iC149](#) and the digital USB scope [iC227](#) are new tools to enable these measurements. This also transforms the oscilloscope, or the PC, into an optical Scope for measuring the actual optical laser diode output.

7) Literature

[1] *50 years of the laser – a technology that has changed the world* (<http://www.50-years-laser.com/>)

[2] Discrete vs. integrated, [Application Note 3](#)

[3] Uwe Malzahn, *Driving diode lasers is straightforward*

(http://www.ichaus.biz/upload/pdf/EuroPhotonics_H89_2004_Driving_Diode_Lasers.pdf)

[4] Laser Webinar [Handout](#)

Introducing iC-Haus

iC-Haus GmbH is one of the leading independent German manufacturers of standard iCs (ASSP) and customized ASiC semiconductor solutions. The company has been active in the design, production and sales of application-specific iCs for industrial, automotive and medical technology for over 25 years and is represented worldwide. The iC-Haus cell libraries in CMOS, bipolar and BCD technologies are fully equipped to realize the design of sensor and actuator iCs, laser/opto iCs, magnetic Hall and optical encoder iCs, driver iCs, and other mixed-signal components. The iCs are assembled either in standard plastic packages or using chip-on-board technology to manufacture complete microsystems, multichip modules, and optoBGA™, the latter in conjunction with sensors.